

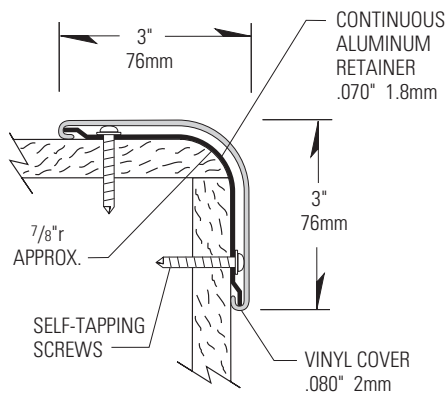

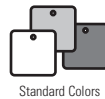



170 High Impact Bullnose Corner Guard



Product
Guide 



-  Provides 3" (76mm) wing with bullnose corner protection
-  Mounted on a sturdy .070" (1.8mm) pre-slotted continuous aluminum retainer
-  .080" (2mm) thick scratch and stain resistant rigid vinyl cover
-  Manufactured in 3' (.91m), 4' (1.22m), 8' (2.44m), 9' (2.74m) and 12' (3.66m) standard heights, custom heights available
-  All mounting fasteners and top and bottom caps are included with each order

IPC.396/REV.4

170 High Impact Bullnose Corner Guard

Suggested Specifications

PART 1 - GENERAL

1.01 SUMMARY

A. Corner guard system for wall protection

1.02 SECTION INCLUDES

A. 170 High Impact Surface Mount Bullnose Corner Guard System

1.03 REFERENCES

- A. American Society for Testing and Materials (ASTM)
- B. National Building Code of Canada (NBC)
- C. National Fire Protection Association (NFPA)
- D. Society of Automotive Engineers (SAE)
- E. Underwriters Laboratory (UL)
- F. Underwriters Laboratory of Canada (ULC)
- G. Uniform Building Code (UBC)

1.04 SYSTEM DESCRIPTION

- A. Performance Requirements: Provide corner guard systems that conform to the following requirements of regulatory agencies and the quality control of IPC Door and Wall Protection Systems, InPro Corporation.
1. Fire Performance Characteristics: Provide UL Classified corner guards conforming with NFPA Class A fire rating. Surface burning characteristics, as determined by UL-723 (ASTM E-84), shall be flame spread of 10 and smoke development of 350 - 450. Provide ULC (Canada) listed corner guards conforming to the requirements of the National Building Code of Canada 1990, Subsection 3.1.13. Surface burning characteristics, as determined by CAN/ULC-S102.2, shall be flame spread of 15 and smoke developed of 35.
 2. Self Extinguishing: Provide corner guards with a CC1 classification, as tested in accordance with the procedures specified in ASTM D-635-74, Standard Test Method for Rate of Burning and/or Extent and Time of Burning of Self-Supporting Plastics in a Horizontal Position, as referenced in UBC 52-4-1988.
 3. Impact Strength: Provide rigid vinyl profile materials that have an Impact Strength of 30.2 ft-lbs/inch of thickness as tested in accordance with the procedures specified in ASTM D-256-90b, Impact Resistance of Plastics.
 4. System Impact Resistance: Provide a corner guard system that resists an impact of 153.9 ft-lbs while producing no visual blemishes upon the vinyl cover surface and no deformations in the vinyl retainers, as tested in accordance with the applicable provisions of ASTM F 476-84, paragraph 18, Impact Test.
 5. Chemical and Stain Resistance: Provide corner guards that show resistance to stain when tested in accordance with applicable provisions of ASTM D-543.
 6. Fungal and Bacterial Resistance: Provide rigid vinyl that does not support fungal or bacterial growth as tested in accordance with ASTM G-21 and ASTM G-22.
 7. Color Consistency: Provide components matched in accordance with SAE J-1545 - (Delta E) with a color difference no greater than 1.0 units using CIE Lab, CIE CMC, CIE LCh, Hunter Lab or similar color space scale systems.

1.05 SUBMITTALS

- A. Product Data: Manufacturer's printed product data for each type of corner guard specified.
- B. Detail Drawings: Mounting details with the appropriate fasteners for specific project substrates.
- C. Samples: Verification samples of corner guard, 8" (203mm) long, in full size profiles of each type and color indicated.
- D. Manufacturer's Installation Instruction: Printed installation instructions for each corner guard.

1.06 DELIVERY, STORAGE AND HANDLING

- A. Deliver materials in unopened factory packaging to the jobsite
- B. Inspect materials at delivery to assure that specified products have been received.
- C. Store in original packaging in a climate controlled location away from direct sunlight.

1.07 PROJECT CONDITIONS

- A. Environmental Requirements: Products must be installed in an interior climate controlled environment.

1.08 WARRANTY

- A. Standard IPC Limited Lifetime Warranty against material and manufacturing defects.

PART 2 - PRODUCTS

2.01 MANUFACTURER

- A. Acceptable Manufacturer: IPC Door and Wall Protection Systems, InPro Corporation, PO Box 406 Muskego, WI 53150 USA; Telephone: 800-222-5556, Fax: 888-715-8407, Internet address: <http://www.inprocorp.com>
- B. Substitutions: Not permitted
- C. Provide all corner guards and wall protection from a single source.

2.02 MANUFACTURED UNITS

A. Corner Guard System

1. 170 BluNose High Impact Bullnose Corner Guard Profile 3" (76mm) x 3" (76mm), 90 degree Bullnose w/ 1 3/16" (30mm) radius to outside of vinyl cover
- 3' (.91m), 4' (1.22m), 8' (2.44m) and 9' (2.74m) standard heights
Custom heights available

2.03 MATERIALS

- A. Vinyl Covers: Snap on cover of .080" (2mm) thickness shall be extruded from chemical and stain resistant polyvinyl chloride with the addition of impact modifiers. No plasticizers shall be added (plasticizers may aid in bacterial growth).
- B. Aluminum Retainers: Continuous aluminum retainer of .070" (1.8mm) thickness shall be fabricated from 6063-T5 aluminum with a mill finish.

2.04 COMPONENTS

- A. Top caps and bottom caps shall be made of injection molded thermoplastics.
- B. Fasteners: All mounting system accessories appropriate for substrates indicated on the drawings shall be provided.

2.05 FINISHES

- A. Vinyl Covers: Colors of the corner guard to be selected by the architect from the IPC finish selection. Surface shall have a pebble texture.
- B. Molded Components: Top caps and bottom caps shall be of a color matching the corner guards. Surface shall have a pebble texture.

PART 3 - EXECUTION

3.01 EXAMINATION

- A. Examine areas and conditions in which the corner guard systems will be installed.

1. Complete all finishing operations, including painting, before beginning installation of corner guard system materials.

- B. Wall surface shall be dry and free from dirt, grease and loose paint.

3.02 PREPARATION

- A. General: Prior to installation, clean substrate to remove dust, debris and loose particles.

3.03 INSTALLATION

- A. General: Locate corner guard as indicated on the approved detail drawings for the appropriate substrate, and in compliance with the IPC installation instructions. Install corner guard level and plumb at the height indicated on drawings.

- B. Installation of 170 High Impact Surface Mount Bullnose Corner Guard:

1. Position the aluminum retainer against the wall, allowing 5/16" (8mm) from the bottom of the aluminum to the top of the cove base or base board for the bottom cap.
2. Secure the aluminum to the wall using 1-1/4" phillips round head, self-tapping screws if mounting on drywall. Use 6 screws per 4' (1.22m) length, 10 screws per 8' (2.44m) length, or 12 screws per 9' (2.74m) length. The aluminum retainer is pre-slotted to aid in the installation. Use the slotted tabs on the top and bottom cap to transfer marks onto the retainer. Holes should be staggered 1/4" from each wing. Transfer the locations of the mounting holes to the wall with a marker. Drill all marked holes on the wall with a 1/4" drill bit and position the alligator anchors into the holes on the wall. Mount the retainer with #10 x 1-3/4" phillips pan head screws and tighten the screws to secure the retainer.
3. Attach the top and bottom caps to the aluminum retainer using two, 1-1/4" phillips flat head, self-tapping screws per cap if mounting on drywall. The mounting tabs for the top and bottom caps overlap the aluminum.
4. Position the vinyl cover on the aluminum retainer to check the fit. Adjust the top cap on the aluminum retainer to obtain a tight fit with the vinyl cover. Starting at the top, push the vinyl cover over the aluminum, pressing over the entire length until the vinyl snaps securely into place.

3.04 CLEANING

- A. At completion of the installation, clean surfaces in accordance with the IPC clean-up and maintenance instructions.

P.O. Box 406 · Muskego, Wisconsin 53150 USA

www.inprocorp.com

Nationwide 800.222.5556/Fax 888.715.8407

International Sales 262.679.5521 / Fax 262.679.5524