

# Stainless Steel Door Edge Protector

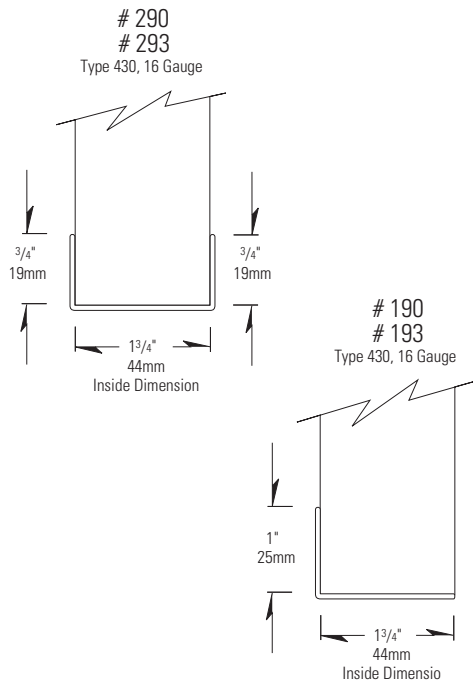

Product  
Guide ①



- ① Available in No. 4 satin finish
- ① Manufactured in 38" (965mm) standard height, custom heights available
- ① Standard Type 430 available in standard 16 gauge, also available in 14 and 18 gauge
- ① Optional Type 304 (Meets NSF Standard 51) available in 16 or 14 gauge
- ① Available with pre-drilled beveled holes or adhesive mount installation

IPC.452/REV.3

# Stainless Steel Door Edge Protector

## Suggested Specifications

### PART 1 - GENERAL

#### 1.01 SUMMARY

A. Door edge protector for door protection

#### 1.02 SECTION INCLUDES

A. Stainless Steel Door Edge Protector System

#### 1.03 SUBMITTALS

A. Product Data: Manufacturer's printed product data for each type of stainless steel door edge protector specified.

B. Detail Drawings: Mounting details with the appropriate adhesives for specific project substrates.

C. Manufacturer's Installation Instruction: Printed installation instructions for stainless steel door edge protector.

#### 1.04 DELIVERY, STORAGE AND HANDLING

A. Deliver materials in unopened factory packaging to the jobsite

B. Inspect materials at delivery to assure that specified products have been received.

C. Store in original packaging in a climate controlled location away from direct sunlight.

#### 1.05 PROJECT CONDITIONS

A. Environmental Requirements: Products must be installed in an interior climate controlled environment.

#### 1.06 WARRANTY

A. Standard IPC Limited Lifetime Warranty against material and manufacturing defects.

### PART 2 - PRODUCTS

#### 2.01 MANUFACTURER

A. Acceptable Manufacturer: IPC Door and Wall Protection Systems, InPro Corporation, PO Box 406 Muskego, WI 53150 USA; Telephone: 800-222-5556, Fax: 888-715-8407, Internet address: <http://www.inprocorp.com>

B. Substitutions: Not permitted

C. Provide all stainless steel door edge protectors and wall protection from a single source.

#### 2.02 MANUFACTURED UNITS

A. Door edge Protectors

1. Stainless Steel Door Edge Protector options

Model #	Size	Gauge	Type	Shape
190	1" x 1-3/4"	16	430	90° L
193	1" x 1-3/4"	16	430	93° L
290	3/4" x 1-3/4" x 3/4"	16	430	90°/90° U
293	3/4" x 1-3/4" x 3/4"	16	430	87°/93° U

38" (965mm) standard height

Custom heights available

#### 2.03 MATERIALS

A. Stainless Steel: Door edge protectors shall be manufactured from Type 430, 16 gauge, stainless steel. Options: Type 430, 14 and 18 gauge; Type 304 (meets NSF Standard 51), 16 and 14 gauge

#### 2.04 COMPONENTS

A. Attachment

1. Adhesive: Field applied heavy duty adhesive

2. Fasteners: Beveled mounting holes and stainless steel screws

#### 2.05 FINISH

A. No. 4 satin finish

### PART 3 - EXECUTION

#### 3.01 EXAMINATION

A. Examine areas and conditions in which the door edge protector will be installed.

1. Complete all finishing operations, including painting and, before beginning installation of door edge protector.

B. Door surface shall be dry and free from dirt, grease and loose paint.

#### 3.02 PREPARATION

A. General: Prior to installation, clean substrate to remove dust and debris

#### 3.03 INSTALLATION

A. General: Locate door edge protector as indicated on the approved detail drawing for the appropriate substrate and in compliance with the IPC installation instructions. Install door edge protector at the height indicated on the drawings.

B. Installation of Stainless Steel Door Edge Protector

1. Surface must be dry, clean and properly sealed.

2. Cement on - Apply a bead of PL Premium Heavy Duty Adhesive in a zig-zag pattern over the back of the door edge protector. Position the door edge protector on the door and apply pressure until a tight fit is achieved.

3. Screw on - Position the door edge protector on the door and attach it using the supplied stainless steel screws.

4. Remove the protective plastic covering from the exposed surface of the door edge protector.

#### 3.04 CLEANING

A. At completion of the installation, clean surfaces in accordance with the IPC clean-up and maintenance instructions.

P.O. Box 406 · Muskego, Wisconsin 53150 USA

[www.inprocorp.com](http://www.inprocorp.com)

Nationwide **800.222.5556**/Fax 888.715.8407

International Sales **262.679.5521** / Fax 262.679.5524